

Autonics Temperature Transmitters with HART protocol KT-502H SERIES

INSTRUCTION MANUAL



Thank you for choosing our Autonics product.
Please read the following safety considerations before use.

■ Safety Considerations

※ Please observe all safety considerations for safe and proper product operation to avoid hazards.

※ ⚠ symbol represents caution due to special circumstances in which hazards may occur.

- ⚠ Warning** Failure to follow these instructions may result in serious injury or death.
- ⚠ Caution** Failure to follow these instructions may result in personal injury or product damage.

⚠ Warning

1. **Fail-safe device must be installed when using the unit with machinery that may cause serious injury or substantial economic loss.** (e.g. nuclear power control, medical equipment, ships, vehicles, railways, aircraft, combustion apparatus, safety equipment, crime/disaster prevention devices, etc.)
Failure to follow this instruction may result in personal injury, economic loss or fire.

2. **Do not use the unit in the place where flammable/explosive gas, high humidity, direct sunlight, radiant heat, vibration, impact, or salinity may be present.**
Failure to follow this instruction may result in explosion or fire.

3. **Do not connect, repair, or inspect the unit while connected to a power source.**
Failure to follow this instruction may result in electric shock or malfunction.

4. **For installing the unit, ground it exclusively and use over AWG 11(4mm²) ground cable.**
Failure to follow this instruction may result in electric shock.

5. **Do not disassemble or modify the unit.**
Failure to follow this instruction may result in fire or electric shock.

6. **Check 'Connections' before wiring.**
Failure to follow this instruction may result in fire.

⚠ Caution

- Use the unit within the rated specifications.
Failure to follow this instruction may result in fire or product damage.
- Use a dry cloth to clean the unit, and do not use water or organic solvent.
Failure to follow this instruction may result in fire or electric shock.
- Keep the product away from metal chip, dust, and wire residue which flow into the unit.
Failure to follow this instruction may result in fire or product damage.

■ Ordering Information

Item	Description	①	②
① Mounting bracket	0 Without bracket	1	With bracket
② Input range	※ 1: To order this unit, write the temperature sensor type and the input range.		

■ Input Type and Range

Input type		Input range (°C)	Input range (°F)	
RTD	DPt100Ω	-200 to 850	-328 to 1562	
	DPt500Ω	-200 to 250	-328 to 482	
	DPt1000Ω	-200 to 250	-328 to 482	
	Cu50Ω	-50 to 150	-58 to 302	
	Cu100Ω	-50 to 150	-58 to 302	
	Ni100Ω	-60 to 180	-76 to 356	
Resistance transmitter	Resistance (Ω)	0 to 400Ω	—	
		0 to 2000Ω	—	
	B (PtRh30-PtRh6)	0 to 1820	32 to 3308	
	E (NiCr-CuNi)	-270 to 1000	-454 to 1832	
	J (Fe-CuNi)	-210 to 1200	-346 to 2192	
	K (NiCr-Ni)	-270 to 1372	-454 to 2501.6	
Thermocouple	N (NiCrSi-NiSi)	-270 to 1300	-454 to 2372	
	R (PtRh13-Pt)	-50 to 1768	-58 to 3214.4	
	S (PtRh10-Pt)	-50 to 1768	-58 to 3214.4	
	T (Cu-CuNi)	-270 to 400	-454 to 752	
	Analog	Voltage	-10 - 75mV	—
			-100 - 100mV	—
-100 - 500mV			—	
-100 - 2000mV			—	

※ The above specifications are subject to change and some models may be discontinued without notice.
※ Be sure to follow cautions written in the instruction manual and the technical descriptions (catalog, homepage).

■ Specifications

Series	KT-502H	
Power supply	10.5-45VDC (with backlight LCD)	
Display method	PV display part : 7-segment 5-digit (character size: W4×H8mm), Parameter display part : 14-segment 8-digit (character size: W2.6×H4.8mm), 52-bar meter	
Display range	-19999 to 99999	
Setting method	HART-protocol (no setting key)	
Response time	1 sec	
Input type	RTD	DPt100Ω, DPt500Ω, DPt1000Ω Ni100Ω, Ni500Ω, Ni1000Ω Cu50Ω, Cu100Ω
	Thermocouple	K, J, T, E, N, S, B, R
Voltage trans. (mV)	Resistance trans. (Ω)	0 - 400Ω, 0 - 2000Ω
		-10 - 75mV
		-100 - 100mV
		-100 - 500mV
Output	DC4-20mA (2-wire)	
Accuracy	±0.3%	
Alarm	Below 3.8mA, Over 20.5mA / Sensor break 3.6mA	
Load	max. (V power supply - 7.5V)/0.22A	
Galvanic insulation	2kVAC (input/output)	
Environment	Ambient temp. -20 to 70 °C, storage: 20 to 80 °C Ambient humi. 0 to 85%RH, storage: 0 to 85%RH	
Explosion class*1	Ex d IIC T6	
Protection structure	IP67	
Material	Body: Aluminum (AlDc.8S), Cover O-Ring: Buna N	
Weight*2	Approx. 1.4 kg (approx. 1.2 kg)	

※1: The explosion class specification is acquired and managed by KONICS.
※2: The weight includes packaging. The weight in parenthesis is for unit only.
※ Environment resistance is rated at no freezing or condensation.

■ Error Display and Troubleshooting

Display	Error	Troubleshooting
Err05	Temperature sensor A, B or all sensors are disconnected.	Check the temperature sensor.
Err06	Temperature sensor B is disconnected.	
Err07	When PV is lower than the low-limit value of set temperature range.	Check low-limit value of the set temperature range.
Err08	When PV is higher than the high-limit value of set temperature range.	Check high-limit value of the set temperature range.

■ Temperature Range Setting

Connect a HART communicator and set temperature range as below by a HART communicator.

Online (Generic)	
1. Device Setup	
2. PV	
3. PV Ao	
4. PV LRV	
5. URV	SAVE

1. PV LRV	
2. URV	
HELP HOME	

PV LRV	0.000
0.000 deg C	
HELP DEL ESC ENTER	

1. PV LRV	
2. URV	
HELP HOME	

PV URV	100.000
100.000 deg C	
HELP DEL ESC ENTER	

1. PV LRV 0.000 deg C	
2. URV 100.000 deg C	
HELP SEND HOME	

- WARNING -
Pressing 'OK' will change device output put 100P in manual

OK

- WARNING -
Return control 100P To automatic control

OK

1. PV LRV 0.000 deg C	
2. URV 100.000 deg C	
HELP HOME	

① Press the key for 3 sec.
Select the '4. PV LRV' by keys and press the key.

② Select '1. PV LRV' (Low temperature range) and press the key.

③ Set Low temperature range and press the (F4) key.

④ Select '2. URV' (High temperature range) and press the key.

⑤ Set High temperature range and press the (F4) key.

⑥ When the set temperature range is correct, press the (F2) key.

⑦ Press the (F4) key.

⑧ Press the (F4) key.

⑨ Check the set temperature range.
Press the (F3) key.
HART communication is OFF.

■ Current Trim Adjustment

Connect a HART communicator and adjust current trim as below by a HART communicator.

1. Device Setup	
2. PV	
3. PV Ao	
4. PV LRV	
5. URV	

① Select the '1. Device Setup' by keys and press the key.

1. Process Variables	
2. Diag/Service	
3. Basic Setup	
4. Detailed Setup	
5. Review	

② Select the '2. Diag/Service' by keys and press the key.

1. Test device	
2. Loop test	
3. Calibration	
4. D/A trim	

③ Select the '4. D/A trim' by keys and press the key.

WARN-Loop should be removed from automatic control	ABORT OK
--	----------

④ Press the (F4) key.

Connect reference meter	ABORT OK
-------------------------	----------

⑤ Press the (F4) key.

Setting fid dev output to 4mA	ABORT OK
-------------------------------	----------

⑥ Press the (F4) key.

Enter meter Value 4.000	HELP DEL ABORT ENTER
-------------------------	----------------------

⑦ Press the (F4) key to set 4 mA display value.

Fid dev output 4.000 mA equal to reference meter ?	1. Yes	2. No	ABORT ENTER
--	--------	-------	-------------

⑧ If output display value is correct, select '1. Yes' and press the (F4) key. If not, select '2. No' and press the (F4) key and re-set the display value.
E.g.) If output display value is 3.89mA, select 3.89 and press the (F4) key.

Setting fid dev. output to 20mA	ABORT OK
---------------------------------	----------

⑨ Press the (F4) key.

Enter meter Value 20.000	HELP DEL ABORT ENTER
--------------------------	----------------------

⑩ Press the (F4) key to set 20mA display value.

Fid dev output 20.000 mA equal to reference meter ?	1. Yes	2. No	ABORT ENTER
---	--------	-------	-------------

⑪ If output display value is correct, select '1. Yes' and press the (F4) key. If not, select '2. No' and press the (F4) key and re-set the display value.

NOTE-Loop may be returned to automatic control	ABORT OK
--	----------

⑫ Press the (F4) key.

Diag/Service	1. Test device	2. Loop test	3. Calibration	4. D/A trim	HELP SAVE HOME
--------------	----------------	--------------	----------------	-------------	----------------

⑬ Press the (F3) key.

Device Disconnected	RETRY QUIT
---------------------	------------

⑭ Press the (F3) key.

1. Offline	2. Online	3. Frequency Device	4. Utility
------------	-----------	---------------------	------------

⑮ Press the (F3) key to complete the adjustment.

■ Dimensions

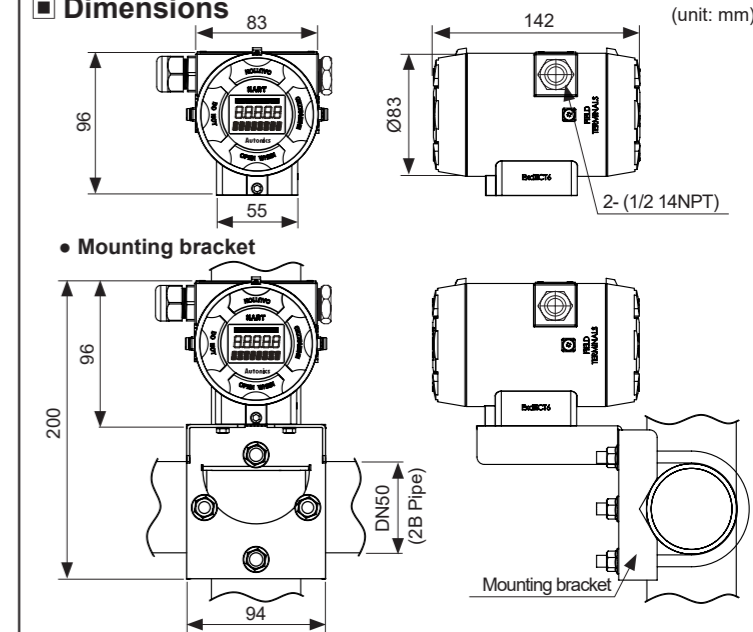

■ Opening Cover

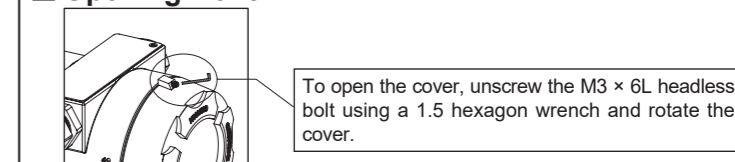

■ Connections

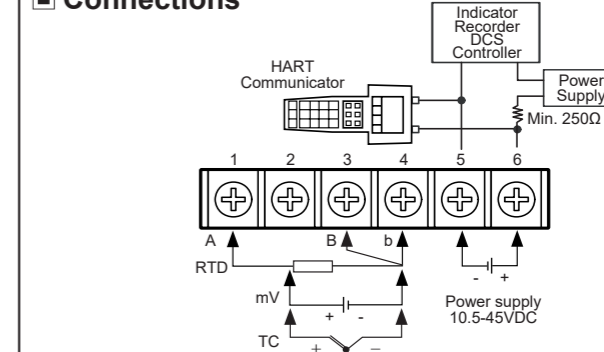

■ Cautions During Use

- Follow instructions in 'Cautions during Use'.
O otherwise, it may cause unexpected accidents.
- Power supply should be insulated and limited voltage/current or Class 2, SELV power supply device.
- Keep away from high voltage lines or power lines to prevent inductive noise.
Do not use near the equipment which generates strong magnetic force or high frequency noise.
- Install a power switch or circuit breaker in the easily accessible place for supplying or disconnecting the power.
- The explosion-proof standard of this unit is Ex d IIC T6, protection structure of this unit is IP67 and the range of max. surface temperature is below 85 °C.
Use the verified explosion-proof electric connection (cable gland or sealing fit ing)
- This unit may be used in the following environments.
 - Indoors (in the environment condition rated in 'Specifications')
 - Altitude max. 2,000m
 - Pollution degree 2
 - Installation Category II

※ The explosion-proof unit is certified and the same specifications which is reported to Korea Gas Safety Corporation. (This unit is manufactured following by the announcement 2013-54 of Ministry of Employment and Labor of Korea.)